

Permanent Magnet (PM) Stepping Motors



PM Stepping Motor & PM Stepping Gearmotor

◆ Product Number Code For PM Stepping Motor

PM 15 15 - 01

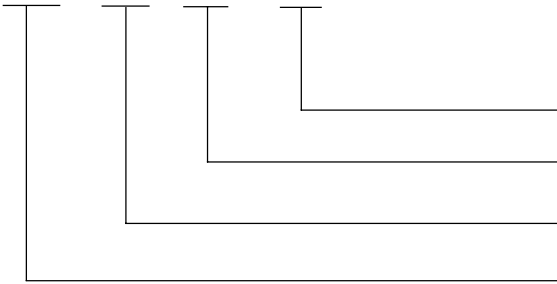

Series number

Body length: 15mm

Frame size: φ 15mm

PM Stepping motor

◆ Product Number Code For PM Stepping Gearmotor

PMG 25 05 - 01

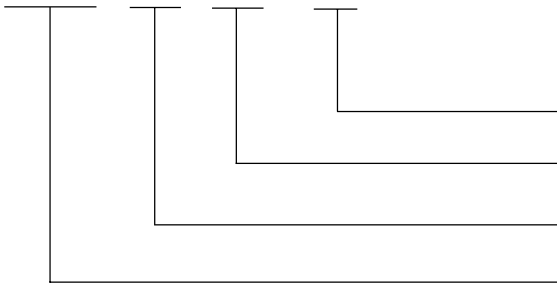

Series number

Ratio: 1:5

Frame size: φ 25mm

PM Stepping gearmotor

PM STEPPING MOTOR

PM15/20/25 SERIES

◆ General Specification for PM Stepping Motor

Item	Specifications
Step Angle Accuracy	± 8% (full step, no load)
Resistance Accuracy	± 10%
Temperature Rise	80°C Max. (rated current, 2 phase on)
Ambient Temperature	-20°C ~ +50°C
Insulation Resistance	100M Ω Min. , 500VDC
Dielectric Strength	500VAC for one minute
Shaft Radial Play	0.06 Max. (450 g-load)
Shaft Axial Play	0.08 Max. (450 g-load)

◆ SPECIFICATIONS:

Model	Step Angle (Deg.)	No. of Phase	Voltage (V)	Current /Phase (A)	Resistance /Phase (ohms)	Holding Torque (g.cm)	Detent Torque (g.cm)	Rotor Inertia (g.cm ²)	Wire Diagram
PM1512-01	18	2	12	0.04	300	40	10	<1	A
PM1512-02	18	2	5	0.5	10	27	6		
PM1512-03	18	2	12	0.065	19	40	10		
PM2018-01	18	4	12	0.24	50	80	25		B
PM2018-02	18	2	5	0.5	10	60	20		A
PM2516-01	15	4	9	0.45	20	140	75		B
PM2516-02	15	4	12	0.4	30	130	75		B
PM2515-01	7.5	2	12	0.24	50	170	45		A
PM2515-02	7.5	4	12	0.25	50	160	35		B
PM2515-03	7.5	4	5	0.5	10	120	45		B
PM2515-04	7.5	2	5	0.5	10	110	40		A

◆ WIRING DIAGRAM:

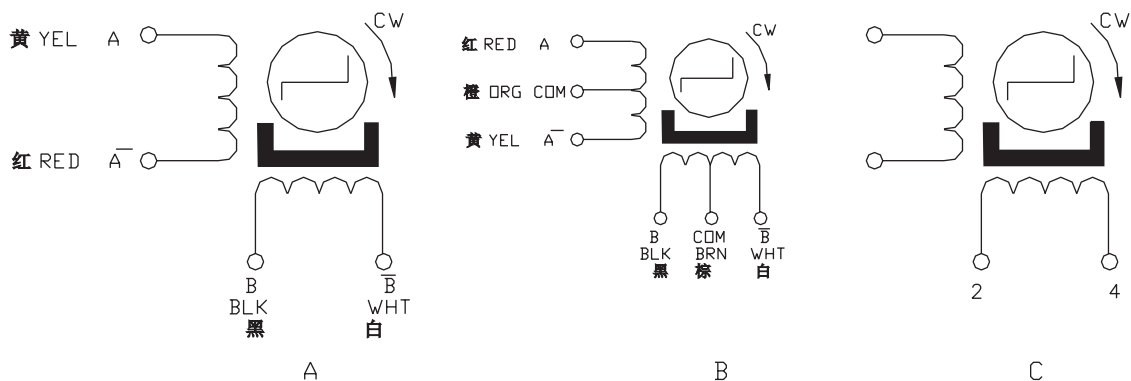

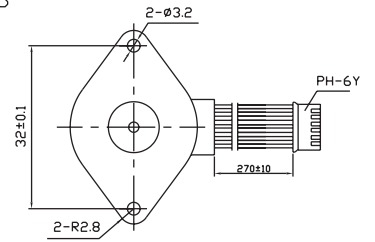
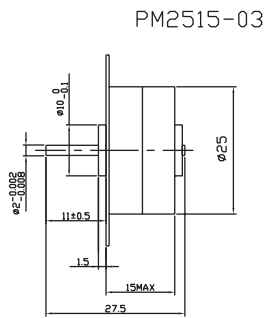
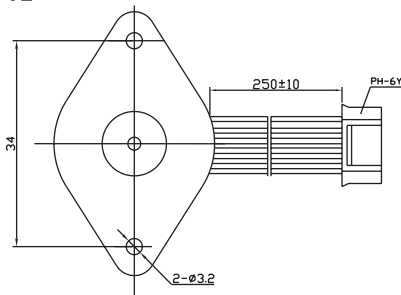
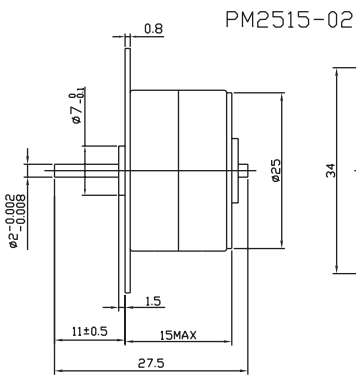
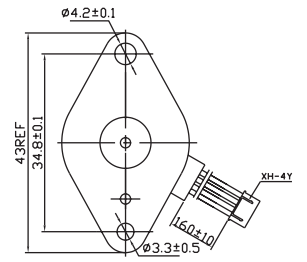
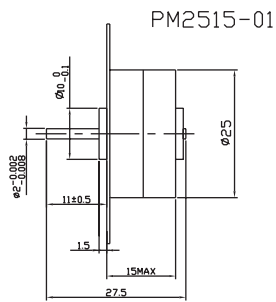
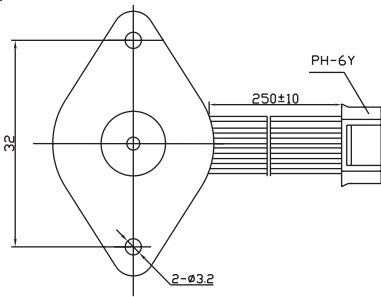
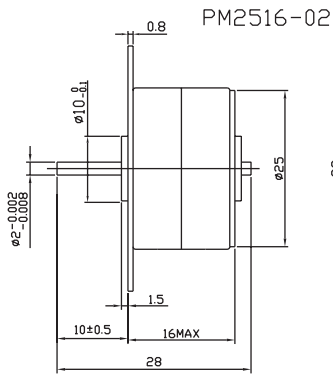

PM2515-04

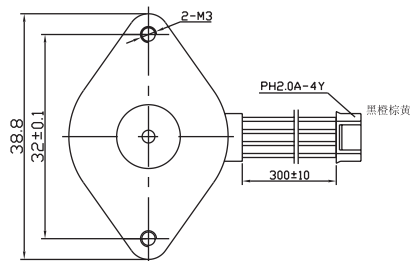
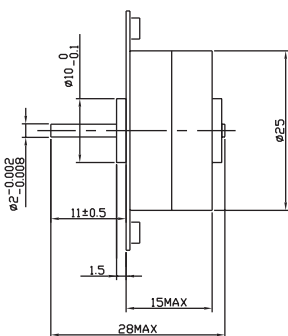

PM STEPPING MOTOR

PM35/42/49/57 SERIES

◆ General Specification for PM Stepping Motor

Item	Specifications
Step Angle Accuracy	± 8% (full step, no load)
Resistance Accuracy	± 10%
Temperature Rise	80°C Max. (rated current, 2 phase on)
Ambient Temperature	-20°C ~ +50°C
Insulation Resistance	100M Ω Min. , 500VDC
Dielectric Strength	500VAC for one minute
Shaft Radial Play	0.06 Max. (450 g-load)
Shaft Axial Play	0.08 Max. (450 g-load)

◆ SPECIFICATIONS:

Model	Step Angle (Deg.)	No. of Phase	Voltage (V)	Current /Phase (A)	Resistance /Phase (ohms)	Holding Torque (g.cm)	Detent Torque (g.cm)	Rotor Inertia (g.cm ²)	Wire Diagram
PM3522-01A	15	2	5	0.46	11	335	125	7.5	A
PM3522-02A	15	4	5	0.46	11	300			B
PM3522-01B	7.5	4	5	0.862	5.8	550			A
PM3522-02B	7.5	2	5	0.5	10				B
PM3522-03B	7.5	2	12	0.2	608	300	65	A	
PM3516-01	7.5	4	12	0.255	47	350	75	9.6	B
PM3516-02	7.5	2	5	0.42	12	800	210	7.5	A
PM4222-01A	7.5	4	12	0.8	15	800	210	9.6	B
PM4222-02A	7.5	2	4.2	0.6	7	550	100		A
PM4222-01B	7.5	2	12	0.13	95	600	110	9.6	B
PM4222-02B	7.5	4	5	0.81	6.2	500	100		A
PM4217-01	7.5	4	12	0.24	50	1700	350	<14.5	
PM4217-02	7.5	2	5	0.59	8.6	1500	425	<12.5	B
PM4930-01	7.5	2	5	0.9	5.5	1200			A
PM5725-01	7.5	4	12	0.6	21				
PM5725-02	7.5	2	5.6	0.625	9				

◆ WIRING DIAGRAM:

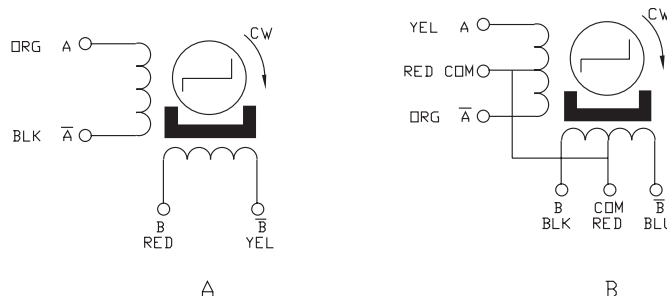

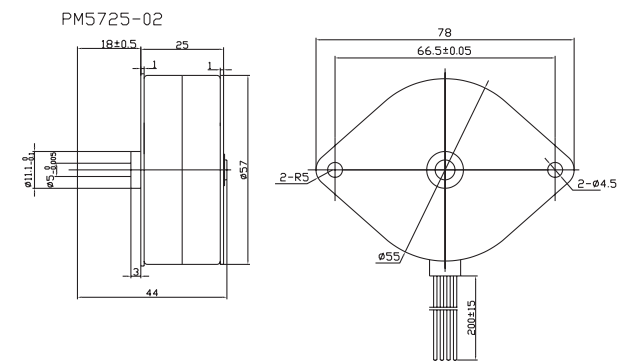
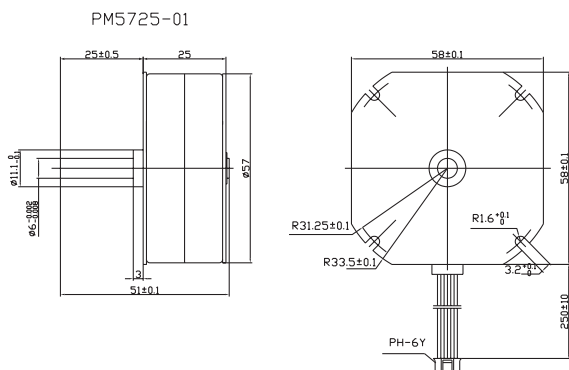
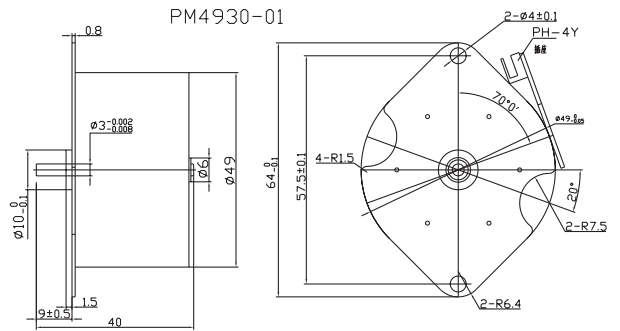
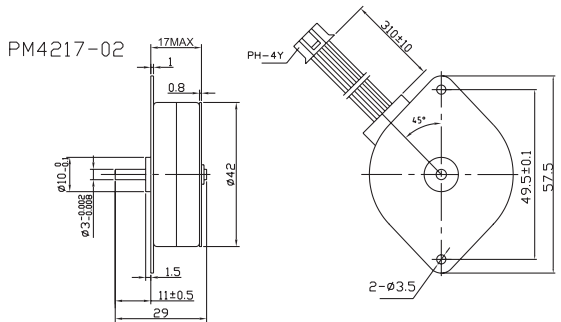
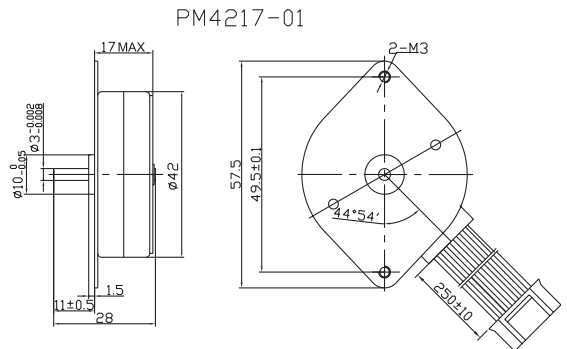
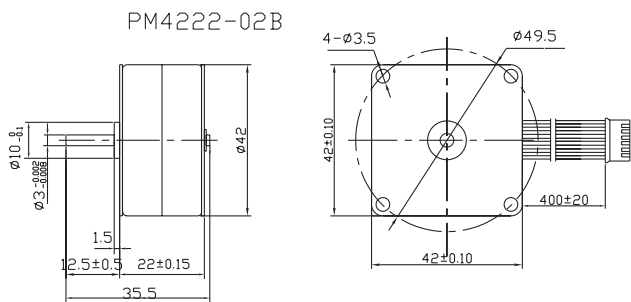
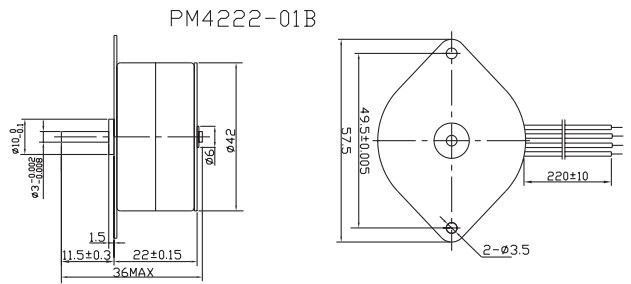
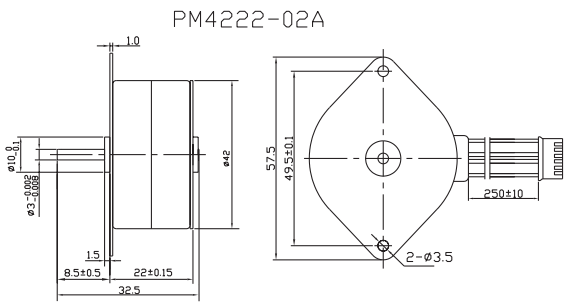

PM STEPPING GEARMOTOR

PMG25/35 SERIES

◆ General Specification for PM Stepping GearMotor

Item	Specifications
Step Angle Accuracy	± 7% (full step, no load)
Resistance Accuracy	± 10%
Temperature Rise	80°C Max. ambient temperature 40°C
Ambient Temperature	-20°C~+50°C
Insulation Resistance	100M Ω Min. ,500VDC
Dielectric Strength	650VAC for one second,leakage current 1mA

◆ SPECIFICATIONS:

Model	Step Angle (Deg.)	No. of Phase	Voltage (V)	Current /Phase (A)	Resistance /Phase (ohms)	Holding Torque (g.cm)	Detent Torque (g.cm)	Ratio	Wire Diagram
PMG2505-01	7.5/5	2	2.6	0.52	5	450	<150	1:5	A
PMG2505-02	15/5	2	3.5	0.365	9.6	500	<150	1:5	
PM2510-01	7.5/10	2	2.8	0.467	6	1400	<500	1:10	
PM2530-01	7.5/30	4	13.3	0.11	120	4000	<1400	1:30	B
PMG3519-01	7.5/19	4	24	0.218	110	12000	<2280	1:19	C
PMG3519-02	7.5/19	4	12	0.4	30	10000	<2600	1:19	
PMG3508-01	7.5/8.4	4	12	0.4	30	1150	<500	1:8.4	
PMG3530-01	7.5/30	4	12	0.4	30	3000	<1500	1:30	
PMG3560-01	7.5/60	4	12	0.4	30	8000	<3000	1:60	
PMG35120-01	7.5/120	4	12	0.4	30	10000	<6000	1:120	

◆ WIRING DIAGRAM:

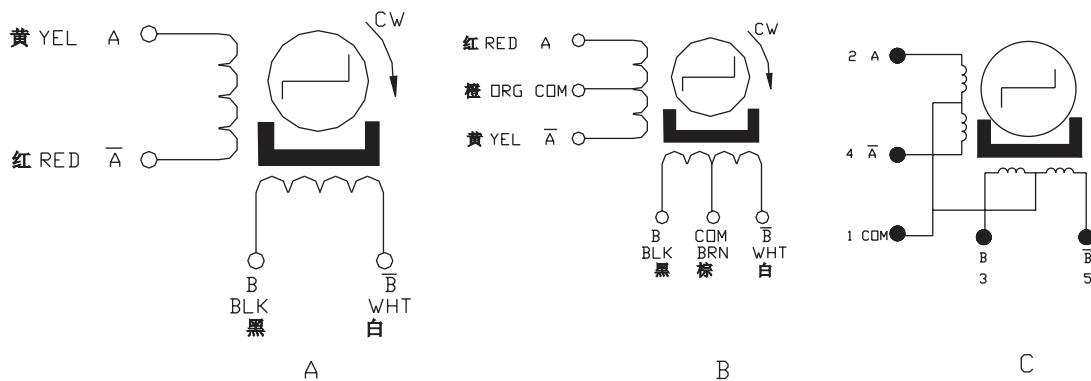

PMG2505-01

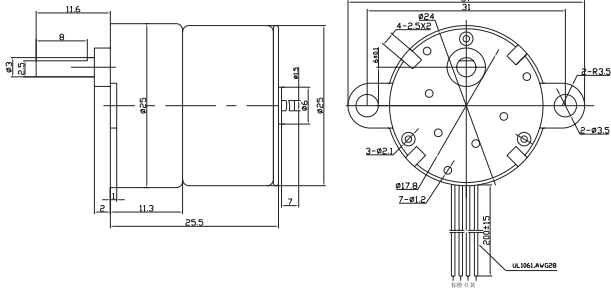

PMG2505-02

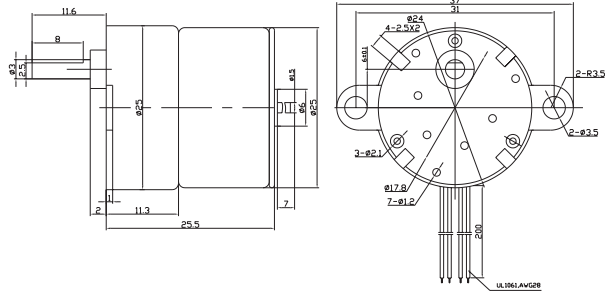

PMG2510-01

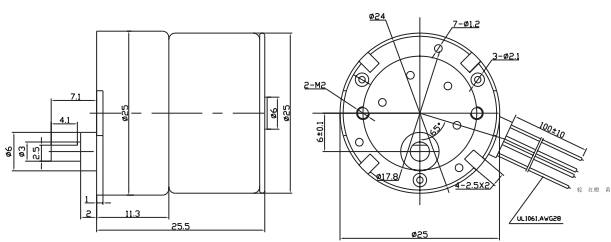

PMG2530-01

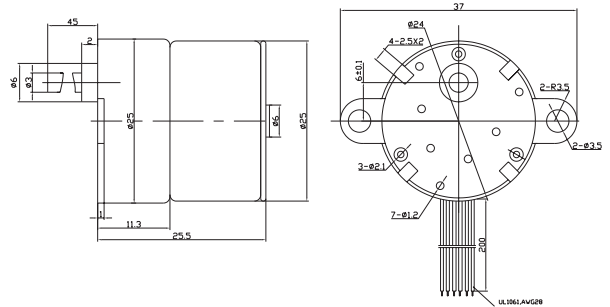

PMG3519-01/02

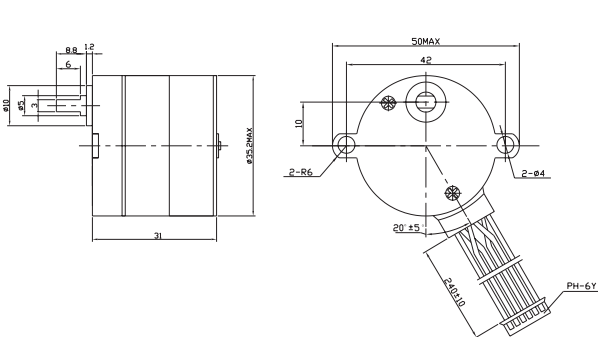

PMG3508/30/60/120-01

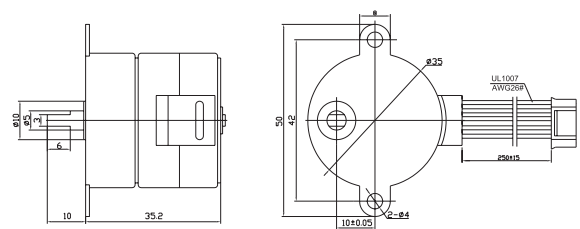

PM STEPPING GEARMOTOR

42BY/40JB4K

PM stepping gear motors

● Indications of the model number

TYPE OF MOTOR ←→ TYPE OF GEAR

42	BY	06	/	40JB	4K	120
Frame	Sort	Voltage	Type of reducer	Max. permissible load	Ratio	
42mm		06:6V 12:12V 24:24V	40mm	4kg.cm	1:120	



● 电动机主要技术参数 Motor technical Data

TYPE	Number of phase	Manner of distribution	Stepping angle	Phase resistance Ω	Exciting voltage V	No-load starting frequency PPS	No-load operating frequency PPS	Rated starting torque g.cm/PPS	Static phase current mA
42BY06	4	2-2	7.5	20±10%	6	450	480	50/300	300
42BY12	4	2-2	7.5	30±10%	12	300	350	140/300	400
42BY24	4	2-2	7.5	200±10%	24	420	330	160/200	126
42BY24	4	2-2	7.5	150±10%	24	500	330	180/200	160

● 减速以后的允许负载 Permissible load of gearmotor

42BY06/40JB4K(20 Ω)

Reduction ratio	10	25	30	50	75	100	120	150
Number of gear trains	2	3	3	4	4	5	5	5
Rated starting torque kg.cm/pps	0.4/300	0.91/300	1.1/300	1.6/300	2.5/300	3.0/300	3.5/300	4.0/300
Stepping angle deg	0.75	0.3	0.25	0.15	0.1	0.075	0.0625	0.05
Max.permissible load of gearhead kg.cm	1.5	2	2	3	3	4	4	4

42BY12/40JB4K(30 Ω)

Reduction ratio	10	25	30	50	75	100	120	150
Number of gear trains	2	3	3	4	4	5	5	5
Rated starting torque kg.cm/pps	1.1/300	2.5/300	3.1/300	4.0/300	4.0/300	4.0/300	4.0/300	4.0/300
Stepping angle deg	0.75	0.3	0.25	0.15	0.1	0.075	0.0625	0.05
Max.permissible load of gearhead kg.cm	1.5	2	2	3	3	4	4	4

42BY24/40JB4K(200 Ω)

Reduction ratio	10	25	30	50	75	100	120	150
Number of gear trains	2	3	3	4	4	5	5	5
Rated starting torque kg.cm/pps	1.2/300	2.8/300	3.5/300	4.0/300	4.0/300	4.0/300	4.0/300	4.0/300
Stepping angle deg	0.75	0.3	0.25	0.15	0.1	0.075	0.0625	0.05
Max.permissible load of gearhead kg.cm	1.5	2	2	3	3	4	4	4

● 外形安装尺寸和接线图 Dimensions And Wiring Diagram

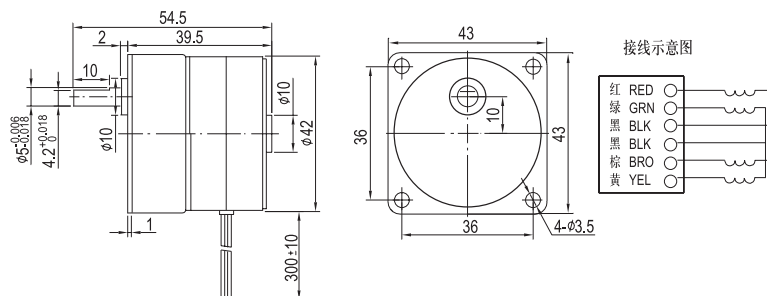

BYJ STEPPING GEARMOTOR

20/24/28/30/35BYJ SERIES

● INDICATIONS OF THE MODEL

35 BYJ 46 — 12 — 110

① ② ③ ④ ⑤

① FRAME ② SORT ③ STEP/REV ④ VOLTAGE ⑤ RESISTANCE

● General Specification for PM Stepping Motor

Item	Specifications
Resistance Accuracy	±7% at 25°C
Temperature Rise	60k Max.(rated voltage, 100pps)
Ambient Temperature	-20°C~+50°C
Insulation Resistance	100M Ω Min.,500VDC
Dielectric Strength	600VAC for one second, leakage current 1mA

● SPECIFICATIONS:

Model	VOLTAGE (v)	No. of phase	Resistance /Phase (ohms)	STEP ANGLE (DEG)	RATIO	PULL-IN TORQUE AT 100PPS (g.cm)	PULL-IN RATE (PPS)	Detent Torque (g.cm)	Wire Diagram
20BYJ48-12-250	12	4	250	7.5/85	1:85	>=340	>=500	>=200	C
24BYJ64-05-025	5	2	25	5.625/64	1:64	>=300	>=400	>=300	A
28BYJ48-12-300	12	4	300	5.625/64	1:64	>=300	>=500	>=200	C
30BYJ48-12-300	12	4	300	7.5/85.25	1:85.25	>=400	>=350	>=400	C
35BYJ46-12-110	12	4	110	7.5/85.25	1:85.25	>=1000	>=500	>=800	B

● WIRING DIAGRAM:

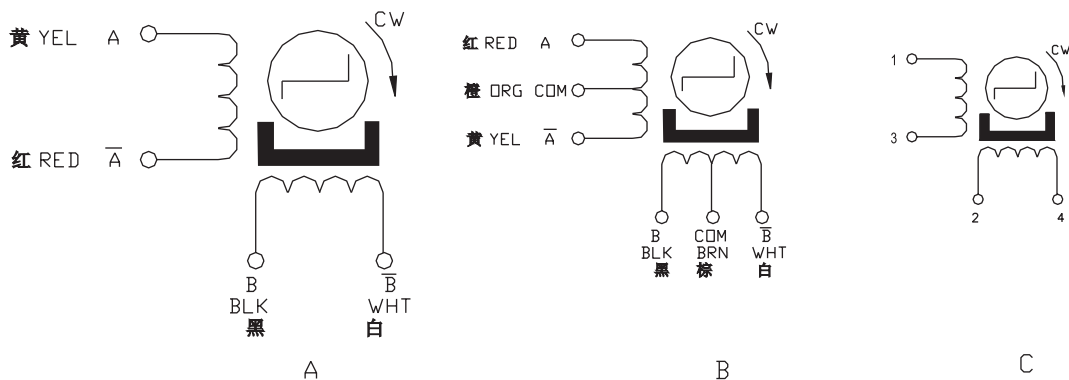

● DIMENSIONS:

20BYJ48-12-300

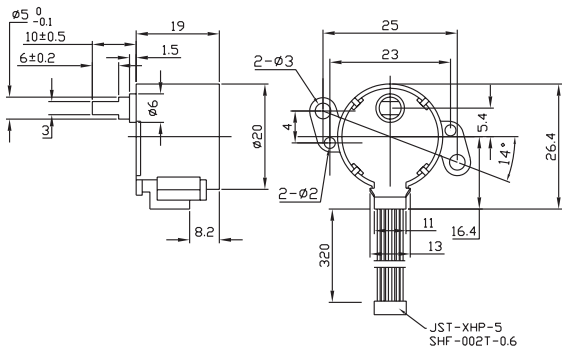

24BYJ64-05-025

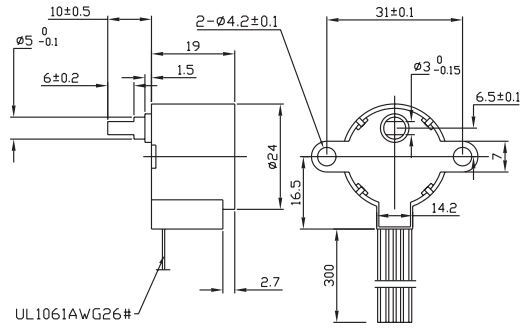

28BYJ48-12-300

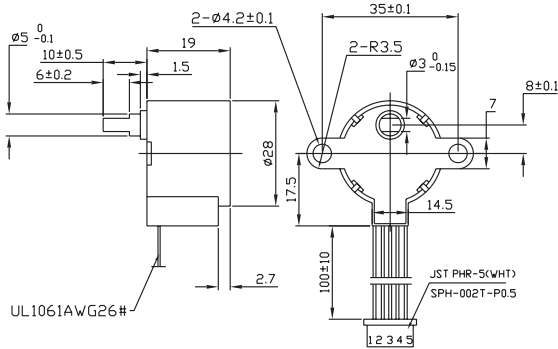

30BYJ48-12-300

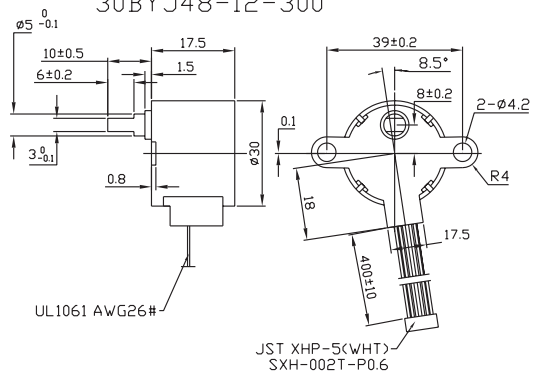

35BYJ46-12-110

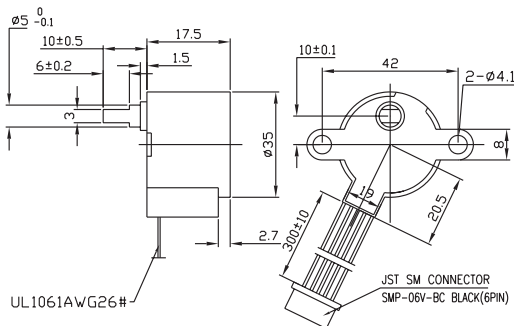

PM STEPPING MOTOR WITH THREAD ON SHAFT

15/20/25/35/42/57BYT SERIES

● SPECIFICATIONS:

Model	Step Angle (Deg.)	No. of phase	Voltage (V)	Current (A)	Resistance (Ω)	Holding Torque (g.cm)	Pull-in Torque (g.cm)	Detent Torque (g.cm)	Leads	Wdg	Fig
15BYT-01	18	2	12	0.07	170	40	5(at 500Hz)	16	UL1571 30AWG	a	1
20BYT-01	18	2	5	0.5	10	60	10(at 200Hz)	20		a .c	2
25BYT48-01	7.5	4	5	0.5	10	120	40(at 100Hz)	45	UL1061 28AWG	a .b	3
25BYT24-01	15	4	9	0.45	20	135	20(at 200Hz)	60	UL1061 28AWG	a .b	3
35BYT48L-01	7.5	4	12	0.22	60	520	50(at 200Hz)	125	UL1007 26AWG	b	4
35BYT24L-01	15	4	24	0.28	85	450	110(at 100Hz)	125	UL1007 26AWG	b	4
35BYT48S-01	7.5	4	5	0.71	7	450	60(at 200Hz)	75	UL1007 26AWG	b	5
42BYT48L-01	7.5	4	12	0.18	70	500	60(at 200Hz)	125	UL1007 26AWG	b	6
42BYT48S-01	7.5	4	12	0.3	40	550	70(at 200Hz)	100	UL1007 26AWG	b	7
57BYT48-01	7.5	4	12	0.6	21	1500	320(at 100Hz)	425	UL1007 26AWG	a .c	8

● WIRING DIAGRAM:

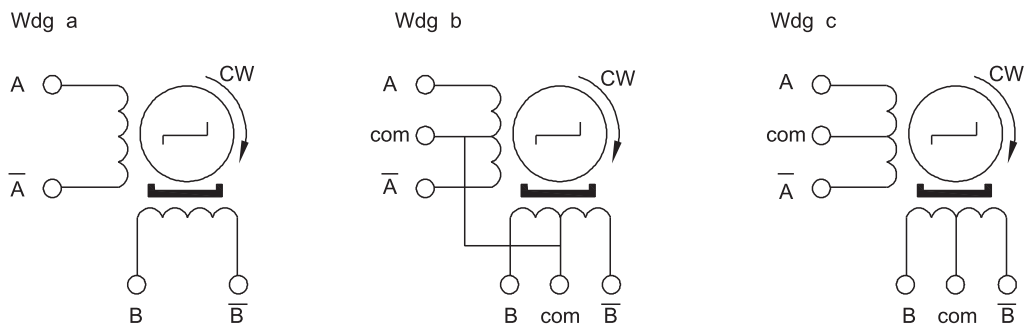

● FIGURE:

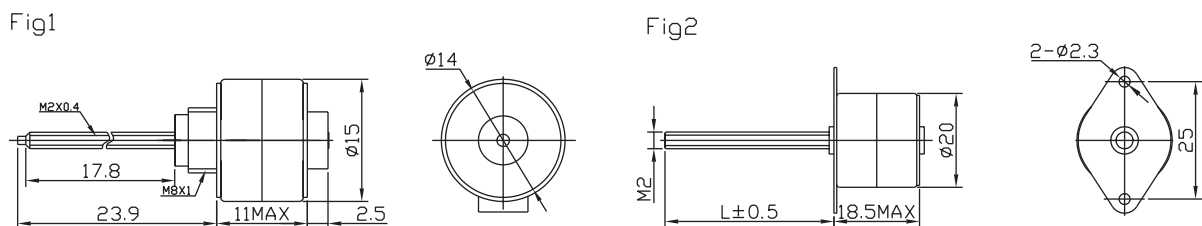

Fig3

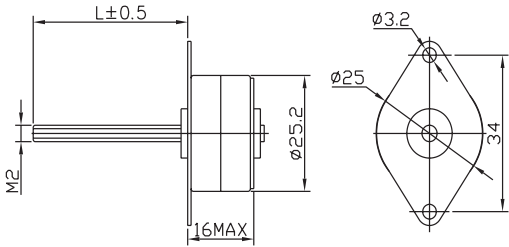

Fig4

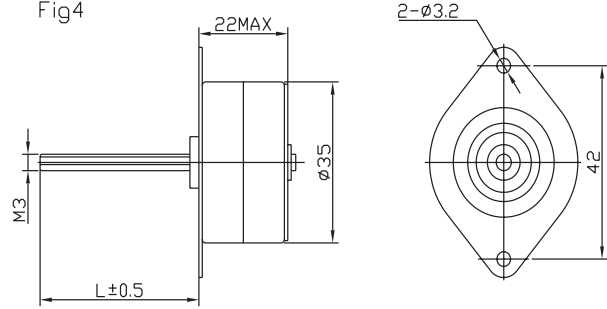

Fig5

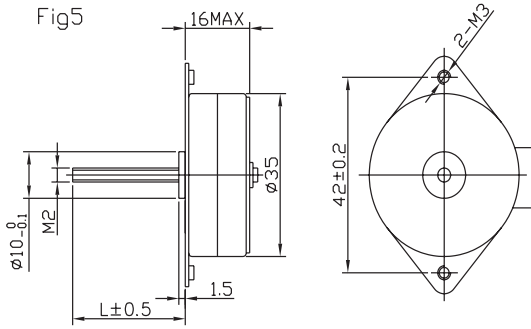

Fig6

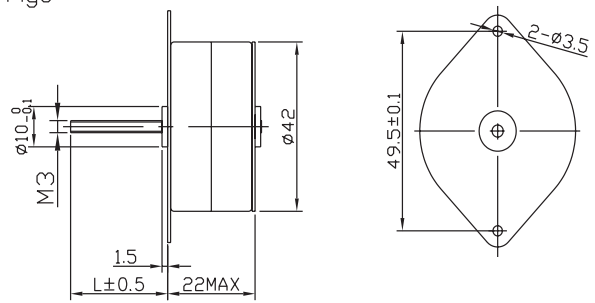

Fig7

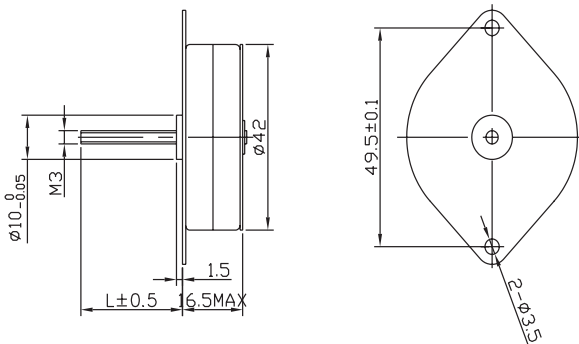
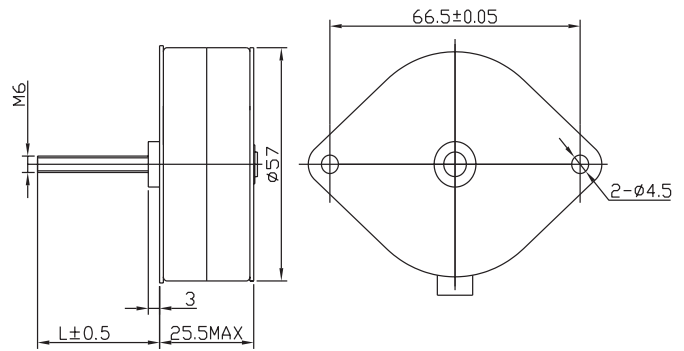

Fig8



LINEAR PM STEPPING MOTOR

25BYZ SERIES

● SPECIFICATIONS:

Captive Non captive

Model	Step Angle (Deg.)	No.of phase	Voltage (V)	Current (A)	Resistance (Ω)	Step Avail (mm)	Push Torque (N)	Journey (mm)	Leads	Wdg	Fig
25BYZ-A01	15	2	12	0.23	53	0.0417	25	12	AF-200 AWG28#	a	1
25BYZ-A02	15	4	12	0.23	53	0.0417	25	12	UL1061 AWG28#	b	1
25BYZ-A04	15	4	5	0.23	22	0.0417	7	12	UL1061 AWG28#	b	1
25BYZ-A05	15	2	5	0.23	22	0.0417	10	12	AF-200 AWG28#	a	2
25BYZ-A01(09)	15	2	12	0.23	53	0.0417	25	12	AF-200 AWG28#	a	3
25BYZ-B01	15	2	12	0.23	53	0.0417	25	40	AF-200 AWG28#	a	4
25BYZ-B02	15	2	6	0.5	12	0.0417	7.5	40	AF-200 AWG28#	a	4
25BYZ-B03	15	2	12	0.5	24	0.0417	30	40	AF-200 AWG28#	a	4
25BYZ-B04	15	4	5	0.23	22	0.0417	30	40	UL1061 AWG28#	b	4

● WIRING DIAGRAM:

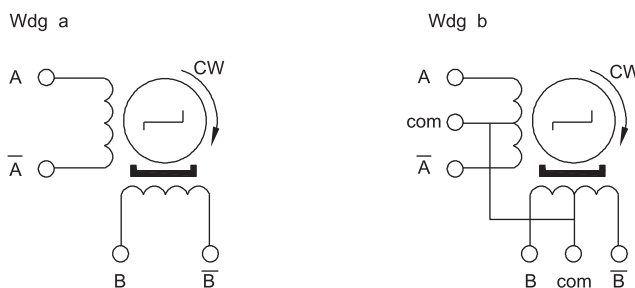

● FIGURE:

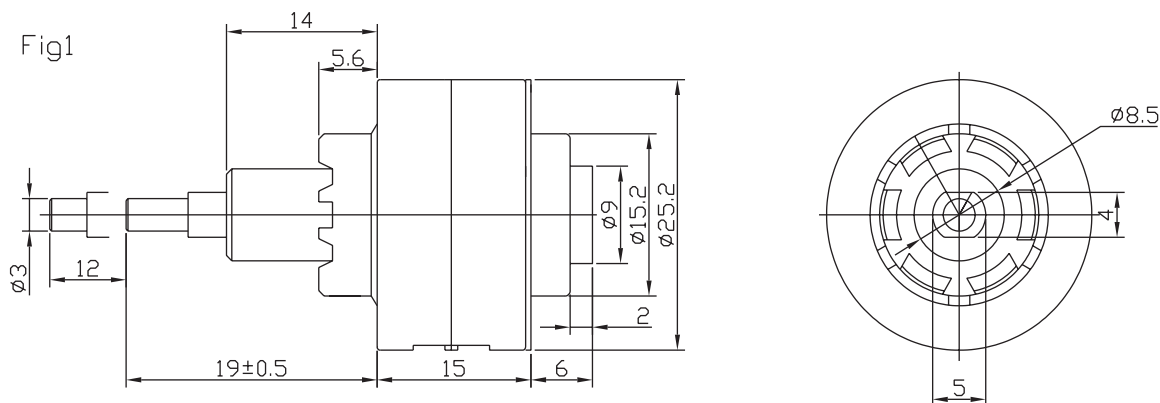

Fig2

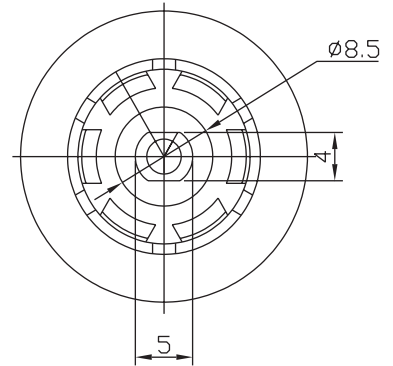
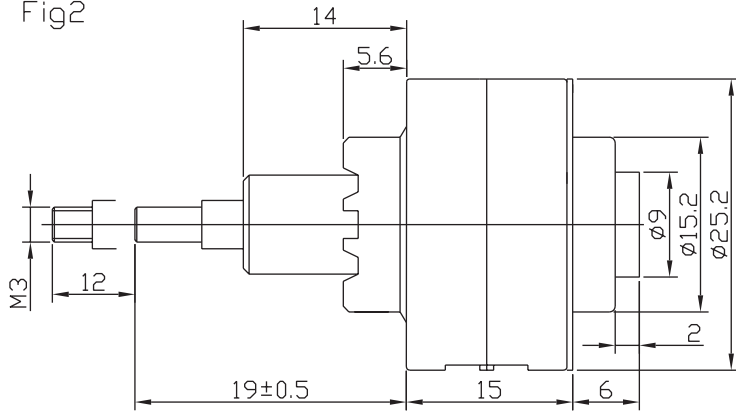

Fig3

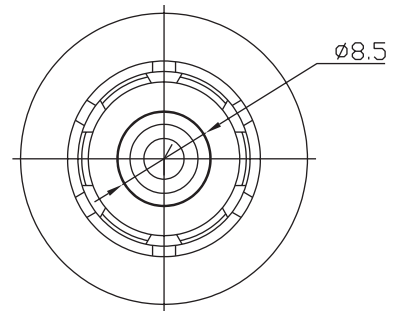
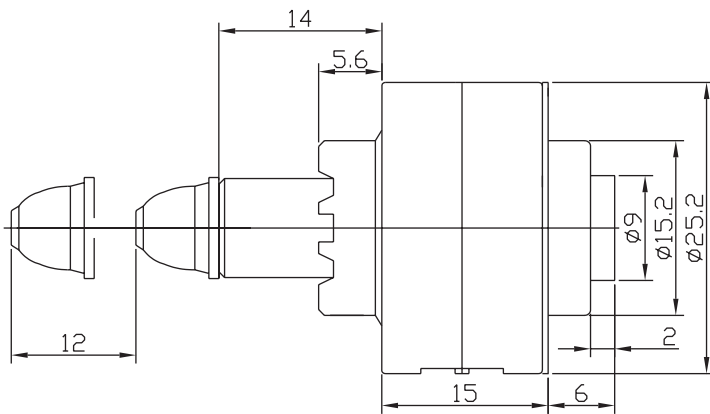
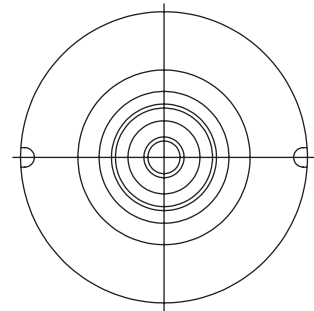
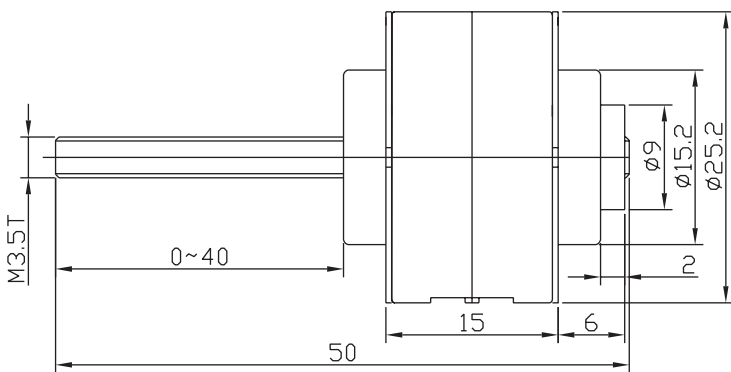

Fig4



LINEAR PM STEPPING MOTOR

35/57BYZ SERIES

● SPECIFICATIONS:

Captive Non captive

Model	Step Angle (Deg.)	No.of phase	Voltage (V)	Current (A)	Resistance (Ω)	Inductance (mH)	Step Avail (mm)	Push Torque (N)	Journey (mm)	Wdg	Fig
35BY42Z01A-02	15	2	12	0.23	53	23.4	0.0417	25	12	a	1
35BY42Z01B-09	15	2	12	0.23	53	23.4	0.0417	25	12	a	2
35BY42Z01B-10	15	2	12	0.23	53	23.4	0.0417	25	12	a	3
35BY42Z01B-10T	15	2	12	0.23	53	23.4	0.0417	25	12	a	4
35BY42Z01B-01TA	15	2	12	0.23	53	23.4	0.0417	25	12	a	6
35BY42Z01B-01TB	15	2	12	0.23	53	23.4	0.0417	25	12	a	7
35BY42Z02C-08	15	2	12	0.23	53	23.4	0.0417	25	12	b	5
57BYZ01-B01	7.5	4	12	0.23	25	29	0.025	31	12	c	8

● WIRING DIAGRAM:

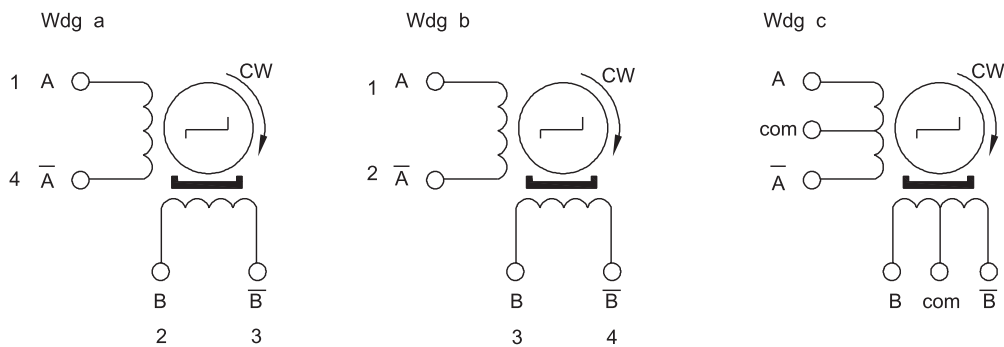

● FIGURE:

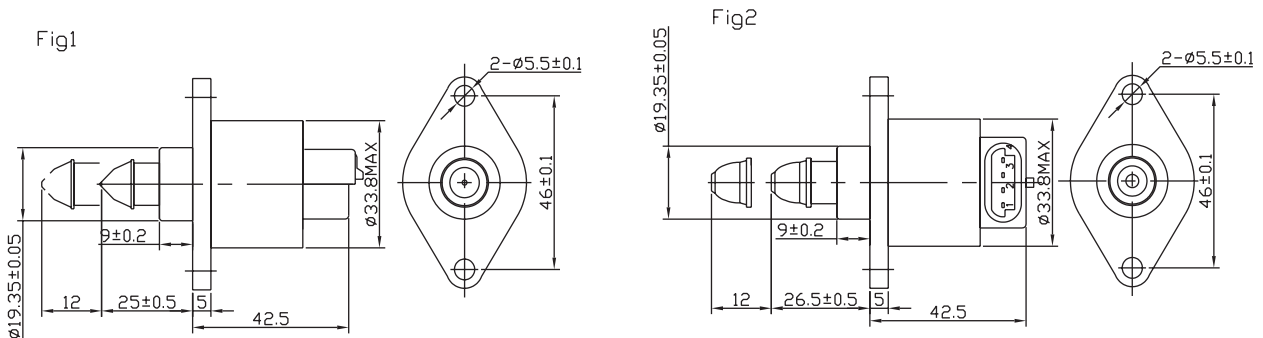

Fig3

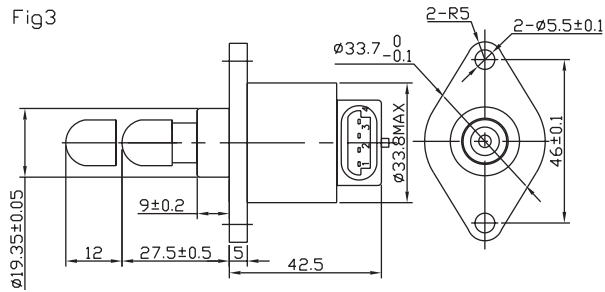

Fig4

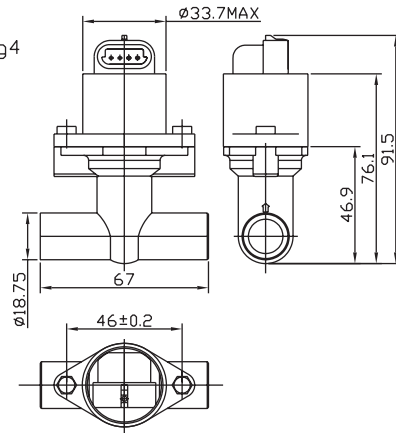

Fig5

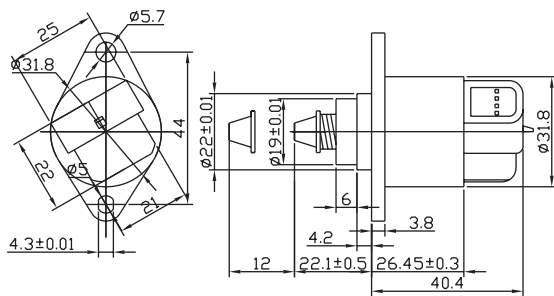

Fig6

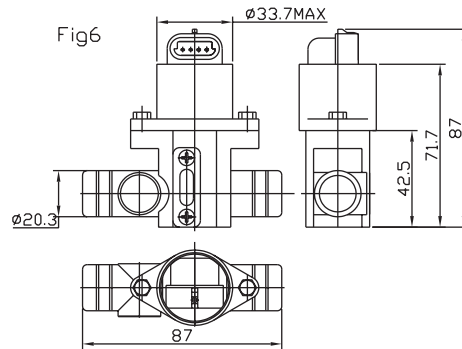

Fig7

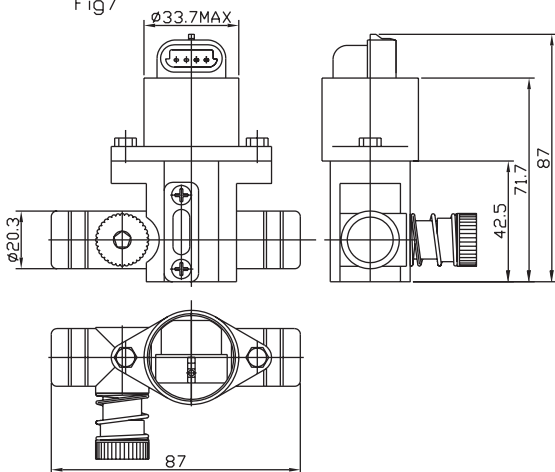

Fig8

